

Beef Quality Assurance

Cattle Handling and Working Facilities

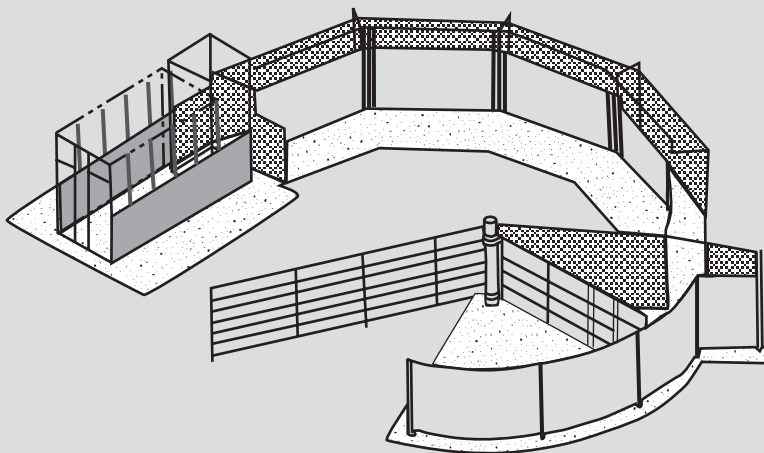

This Ohio Beef Quality Assurance project on animal handling is funded by a grant from the National Cattlemen's Beef Association.

 For-sale publication

Copyright © 2002, Ohio State University Extension

All educational programs conducted by Ohio State University Extension are available to clientele on a nondiscriminatory basis without regard to race, color, creed, religion, sexual orientation, national origin, gender, age, disability or Vietnam-era veteran status.

Keith L. Smith, Associate Vice President for Agricultural Administration and Director, OSU Extension

TDD No. 800-589-8292 (Ohio only) or 614-292-1868

10/02—5M—123456

Cattle Handling

You've heard of horse sense. Well, to get cattle to do what you want takes knowledge of animal behavior, access to good facilities, and proper handling techniques. All of this together adds up to cow sense! Animal-related injuries to employees can be due to preoccupation, impatience, or anger by the animal or the handler! During these moments, a livestock handler really needs to understand animal behavior. Well-designed facilities won't make up for a lack of cow sense at this point.

Not understanding how cattle perceive their world can make for a long day for you — and your cattle. For example, a styrofoam cup that has fallen into the working alley can make cattle balk. A shadow or a flapping shirt on a post or some other distraction can prevent smooth cattle flow. If you are having trouble working a set of cattle, try looking at the world from their perspective.

How Cattle Perceive Their World

Cattle really see the world differently. A cow may see more than you see and is often distracted by motion off to the side. However, she doesn't see the world as clear and sharply focused as humans see it, and it takes her more time to process what she has seen. Cattle have panoramic vision in excess of 300 degrees and only have a blind spot directly in the back of their heads. Human vision, by comparison, is roughly 180 degrees, and we have a much larger blind spot.

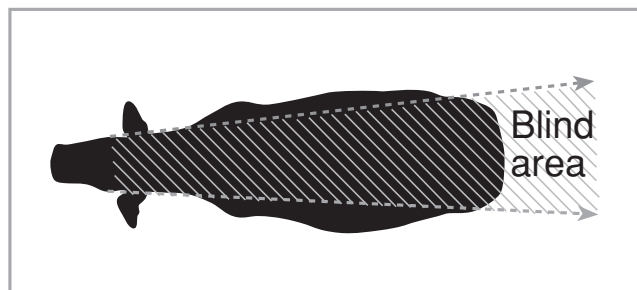

Figure 1. Cattle can see 300 degrees around them, with a blind spot only directly in the back of their heads.

While their field of vision is practically unlimited, cattle have poor depth perception of nearby objects and have limited vertical vision. Cattle must lower their heads to focus on something on the ground because they only have about 60 degrees of vertical vision, compared to 140 degrees for humans. Due to their limitation in vertical vision and their lack of ability to focus quickly, a shadow on the ground appears to them to be a three-mile deep crevasse!

Handlers can help reduce distractions and shadowing by taking these limitations into consideration and using a solid-sided working alley. Also, uniformity in color of handling facilities will reduce balking. Curved, solidly enclosed, and well-lighted working facilities take advantage of these senses, along with the animal's strong desire to find an avenue of escape when confined.

Cattle also hear differently than humans. They can hear both lower volume and higher frequency sounds better than people. It may be the sound of your truck, with feed in it, more than the sight of the truck, that makes those cows "come a runnin'."

Cattle hear extremely well, but the trade-off is that they have less ability to locate the source of a sound. People can pinpoint where a sound came from within 5 degrees, whereas cattle can only isolate the source down to about 30 degrees.

Be mindful of cattle with severe sight problems, such as an advanced case of cancer eye, as they will rely to a greater extent on their sense of hearing. Thus, they may suddenly swing around to investigate a noise.

Comfort/Flight Zone Affects Reactions

People and cattle have a comfort/flight zone that affects how we react.

In many Western cultures, two feet is considered the comfort zone for conversing with another person. In some other Eastern regions of the world, six inches is considered normal. At parties, you might observe Western speakers backing up to seek their comfort zone and Eastern speakers following them to maintain their comfort zone. Also, consider that we typically turn and face someone who is talking to us.

Just as we have some predictable behaviors, so do cattle. Understanding this behavior can be very useful in designing cattle-handling facilities.

The flight zone (comfort zone) is the animal's personal space. The flight zone may be five to 25 feet for tame cattle or feedlot cattle and 300 feet for some wild cattle. The flight zone increases when the approach is from the head, and the flight zone also increases when cattle are excited. The flight zone decreases when animals are in a single file chute.

Cattle will normally move effectively if the handler works on the edge of the flight zone. Deep invasion of the flight zone can cause animals to panic. In Figure 1, Position A is the location outside of the flight zone where animals will stop moving forward, and Position B, inside the flight zone, will cause the animal to move away from the handler.

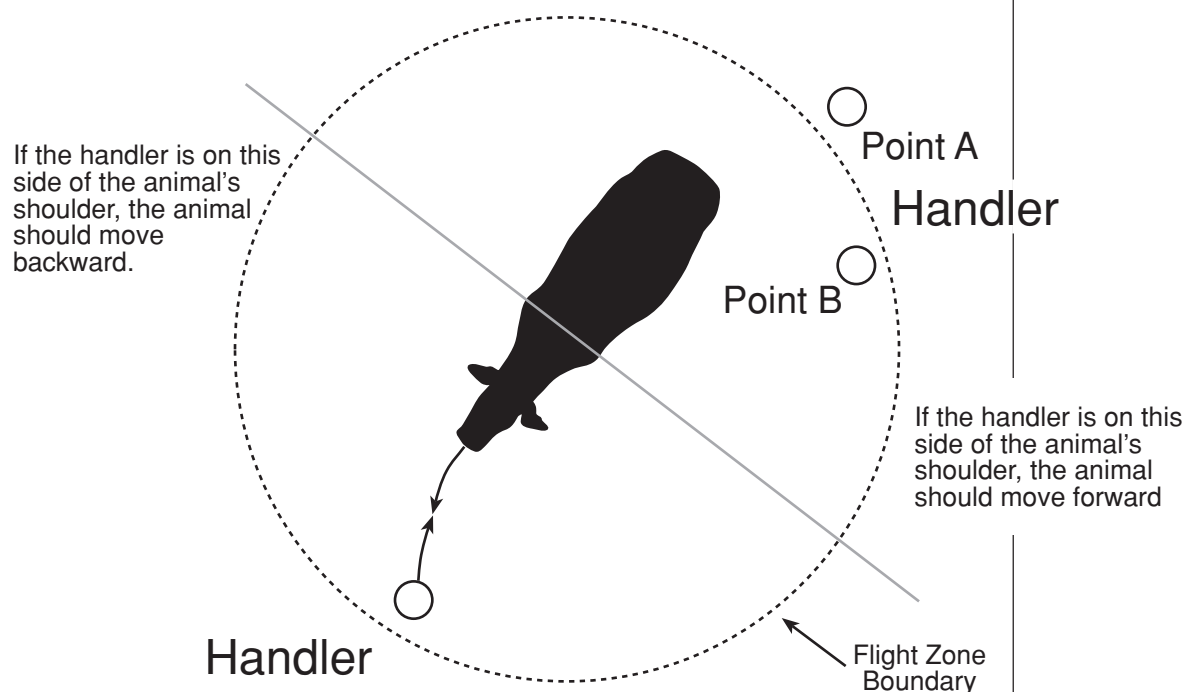

Figure 2. The handler can control the movement of cattle by taking a position in relation to the animal's flight zone. If the handler takes up a position at Point A, which is outside the flight zone, the cattle will stop moving forward. If the handler moves to Point B, which is inside the animal's flight zone, the animal will move away from the handler.

Entering the Flight Zone

Livestock handlers need to understand the flight zone and the point of balance. The point of balance for cattle is typically at the shoulder. To make an animal move forward, the handler should stand behind the point of balance. To move the animal backward,

the handler stands in front of the point of balance. The animal may try to turn if the handler enters the animal's blind spot. Therefore, don't walk directly behind an animal, but off to the side so you can be seen.

Careful, quiet handling of cattle will help improve productivity. Stress imposed by handling and transport can have detrimental effects on weight gain, rumen function, reproductive function, and the immune system. Quiet handling reduces stress-related meat-quality problems such as dark cutters. The amount of stress imposed on an animal is an interaction involving previous experience and genetics.

How quiet your cattle are is at least partially a function of how they are worked. Cattle can remember rough handling. While most cattle will calm down when they are handled quietly, a small percentage of them may remain excited. Highly excitable cattle should be culled. To accurately cull for temperament, there should be a minimum of two observations. More than one evaluation is required to avoid culling a good animal that became excited because an animal next to it became agitated. A behavior classification table helps in assessing which animals should be culled.

Behavior Classification	
1 = Docile	Gentle; handles quietly; slightly elevated respiration.
2 = Restless	More active; elevated respirations but settles down after joining the group once again.
3 = Nervous	Constant movement; occasionally bumps fences and gates; settles down only after several minutes after returning to the group.
4 = Flighty	Agitated by handling and avoids handlers; bumps into gates and fences; always seems to watch handlers when approaching the group.
5 = Aggressive	Bumps gates and fences and might be willing to challenge handlers; attempts to jump fences and gates.
6 = Very Aggressive	Very aggressive toward handlers; jumps and bellows while in the chute. Exits chute frantically and may still exhibit aggressive behavior.

If an animal becomes very excited, 20 to 30 minutes are required for its heart rate to return to normal. For this reason, many packers have “standing” pens to allow cattle to calm down prior to harvest. Many practitioners of artificial insemination also try to sort cattle and let them relax prior to breeding.

Steps such as reducing yelling and minimizing electric prod usage should be considered. If a tool is needed, a stick with a plastic bag on the end or wands that rattle may be useful. Solid sides on chutes and crowd pens help keep animals calmer. Solid sides provide the most advantage when wild cattle are worked and have less effect on tame animals.

Defensive Animals

Horses usually kick directly toward the rear. Cattle are “round-house” punchers. Cows kick forward and out to the side. Cows also have a tendency to kick toward a side with pain. So, if a cow is suffering from mastitis in one quarter, consider approaching her from the opposite side of the affliction. Calves can kick directly backwards and can have a quick “round-house” punch.

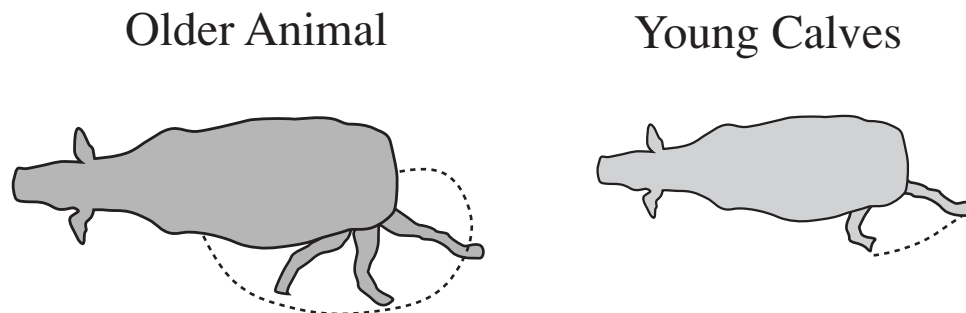

Figure 3. Cattle exhibit a “round-house” punch and kick forward and out to the side.

Cattle exhibiting maternal instincts are usually more defensive and difficult to handle. Removal from a familiar pasture or pen can cause animals to react unexpectedly. Shadows, yelling, and contrasts in lighting can further excite animals and make their behavior unpredictable. Similar problems occur when animals are moved away from feed, separated from the herd, or approached by an unfamiliar person. It is usually easier to take two or three additional animals when you want to work only one of them.

Never prod an animal when it has no place to go. Cattle that become upset during handling and/or that have a bad disposition may adopt a “fight” rather than “flight” behavior. When entering an enclosed area with cattle, you should consider your escape routes — a fence, a tree, or a post.

Diseases

Handlers should also be concerned with disease transmission. Illnesses that can be transmitted back and forth between humans and animals include leptospirosis, rabies, brucellosis, salmonellosis, and ringworm. A livestock producer can contract some illnesses through animal bites, handling an infected animal, or disposing of infected tissues. To reduce exposure to disease, use basic hygiene and sanitation practices, such as washing your hands after working with any animals.

To Reduce Exposure to a Livestock Accident or Illness

- Understand animal behavior.
- Provide proper and safe facilities.
- Protect against diseases by using good sanitation practices.
- Wear appropriate attire.

Working Facilities

Curved Working Chutes

A curved working alley takes advantage of an animal’s natural behavior to turn away from potential danger or unpleasant sites or sounds. Curved working facilities prevent the animal from seeing the squeeze chute or truck until they are almost upon it. A facility with solid sides is likely to require a catwalk.

Cattle like to follow each other. Each animal should be able to see the one ahead of it. Blocking gates in a chute need to be see-through gates, so cattle can see the animal ahead. If the animal views a dead-end, it will balk. Make single-file chutes at least 20 feet long.

Uniform lighting can help avoid shadows. Cattle in the dark will move toward the light. If you are loading at night, use a frosted

light in the truck or shine your flashlight into the truck. Avoid glare in their faces. Livestock tend to balk if they are forced to look into the sun. Position loading and squeeze chutes north and south for summer handling.

Response to Movement or Strange Sights

A white styrofoam cup in the bottom of the working chute will cause the entire herd to balk. Cattle also balk at moving or flapping objects. Therefore, do not place your jacket on a strategic fence post in the working area. Use solid sides for the construction of crowding pens, single-file chutes, and loading chutes. Stand back from the head gate so that the cattle cannot see you or at least think they can escape past you.

Bruises

Bruises cost the cattle industry millions of dollars each year. A large loin bruise is a significant economic loss per animal. Bruised meat has to be trimmed off and cannot be used for human consumption. When cattle become excited, they are more likely to bump into gates, truck doors, and each other. Moving cattle at a slow walk will reduce bruises.

Overloading trucks will greatly increase bruising. Although over crowding can increase bruising, having too few cattle can also increase bruising.

Table 1. Recommended Truck-Loading Densities.

Feed-Fed Steers or Cows, Average Weight	Horned or Tipped or More Than 10% Horned or Tipped	Polled or Dehorned
lbs.	sq. ft.	sq. ft.
800	10.9	10.4
1,000	12.8	12.0
1,200	15.3	14.5
1,400	19.0	18.0

From Grandin, T. *Reducing Bruising in Cattle*. BCH-4410.

Several surveys have shown that horned cattle have twice as many bruises compared to polled or dehorned cattle. Having even a few horned cattle can increase bruising. Dr. Temple Grandin observed in one study that fed cattle with 25 to 50 percent horns had 10 percent bruises. Elimination of horns can lower this figure to 2 to 5 percent. Tipping (cutting off parts of the horn) does not reduce bruising.

Bumping into a flat, wide surface is less likely to cause bruises compared to bumping into an elevated or sharp edge. Broken boards, protruding gate latches, and slick surfaces that allow falling will increase bruising. Consider regrooving concrete when it becomes too smooth. If you are getting reports of bruising, walk through your handling facility and look for the following situations.

Loin bruises

- Narrow gates, horns
- Gates hitting the side of the animal
- Protruding gate latches, boards, and sharp edges

Shoulder Bruises

- Rough handling
- Presence of horns
- Broken flipper gates in runways
- Protruding gate latches, boards, and sharp edges

Back Bruises

- Improperly adjusted one-way gates
- Vertical gates hitting the back (should be padded)
- Tall cattle hitting their backs when exiting the bottom compartment of a semi-trailer

Many of these bruises can be prevented by repairing equipment and working cattle at their pace and not ours.

Basic Corral Design

Working facilities are needed to carry out basic management practices. Some small producers feel that working facilities are too expensive, but without proper facilities, basic management practices are not done. Not doing basic management practices such as dehorning and castration can lead to economic losses as a result of discounts on your calves. Handling facilities also increase the safety for humans when working animals.

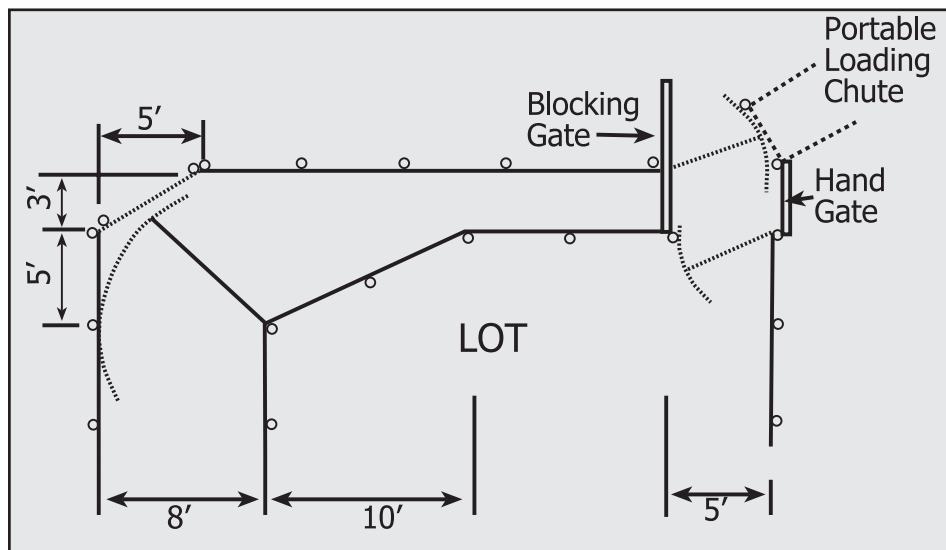

Planning

The goal is to develop a design that accommodates your cattle working needs while making safe and efficient use of available labor and reducing stress and bruising of animals.

Site Selection

Accessibility by people, trucks, and trailers is paramount for a working corral. This accessibility must be convenient even in adverse weather.

Normally, the easiest place to pen cattle is along the fence, especially in a corner of a pasture. Ideally, this location would be where several pastures converge. The pasture fence in proximity to the corral may get additional pressure from cattle pushing on it. Therefore, larger posts and additional bracing may be needed in this part of the pasture fence.

Look for high, well-drained sites. Avoid locations with slopes of greater than 10 degrees (about two inches per foot). Build facilities near electric and water, if possible. However, avoid building adjacent to residences where dust, flies, noise, and odor might be grounds for a nuisance suit. Here is a checklist of items to consider when locating a cattle-handling facility.

Consider These Factors When Locating a Working Facility for Cattle

	Excellent	Good	Poor
1. Accessibility in various weather conditions	<input type="checkbox"/>	<input type="checkbox"/>	<input type="checkbox"/>
2. Proximity to various pasture sites	<input type="checkbox"/>	<input type="checkbox"/>	<input type="checkbox"/>
3. Condition of pasture fence in proximity to corral	<input type="checkbox"/>	<input type="checkbox"/>	<input type="checkbox"/>
4. Drainage from corral is acceptable	<input type="checkbox"/>	<input type="checkbox"/>	<input type="checkbox"/>
5. Electricity and lighting available	<input type="checkbox"/>	<input type="checkbox"/>	<input type="checkbox"/>
6. Proximity to neighbors	<input type="checkbox"/>	<input type="checkbox"/>	<input type="checkbox"/>

An inexpensive working facility can be built in the corner of an existing barn or lot. Regardless of size or type of operation, there are six basic sections in a well-designed working facility.

Basic Sections in a Well-Designed Working Facility

1. Holding pens
2. Alley from pens to working area
3. Crowding pen/tub
4. Working alley
5. Restraining area/squeeze chute
6. Loading area

Holding Pens

Keys to good holding-pen design are having enough pens to meet your needs, having them of sufficient size so animals cannot get past you, and having an easy animal flow to and from the working area. More than one pen will probably be needed so that you can sort cattle into groups.

One of the most common flaws in existing corrals is having a holding pen that is too large. Cattle can easily get past you when you are trying to move them out. One of the easier “refits” to an existing corral is splitting this large pen into two pens. This helps to address the other most common design flaw of existing corrals — not having enough pens for sorting.

Common design flaws of existing corrals are:

1. Pens too large
2. Inadequate number of pens for sorting
3. Poor placement of gates
4. Not enough gates
5. Confusing animal flow to and from the working facility

Smaller pens may be needed as hospital pens and to quarantine newly arrived animals. Provide a source of water and shade in one of the holding pens as a sick or quarantine area. You may want to take into account in what order you want to work cattle groups and thus this may affect pen placement. Keep in mind the fact that current pen placement affects possible corral expansion in the future.

Allow 20 square feet for each cow and 14 square feet for each calf. The area of a square or rectangular pen is equal to the length times the width. For example, a pen with an area measuring 30 feet by 40 feet equals 1,200 square feet. This will accommodate about 35 cows with calves. The following example illustrates how the value of 35 cows with calves was calculated:

$$\begin{array}{r} 20 \text{ sq. ft. per cow} \\ + \text{ 14 sq. ft. per calf} \\ + \text{ 34 sq. ft. for a cow with a calf} \end{array}$$

$$1,200 \text{ sq. ft. pen} / 34 \text{ sq. ft.} = 35 \text{ cows with calves}$$

Alley From Pens to Working Area

Typically, cattle are moved to the working area through an alley. This can be a common alley for cattle going to or returning from the working area. In larger operations, a second alley allows a continuous flow of cattle from the holding pens to the working area and back to their pens. Evaluate your corral design and determine if animal flow to and from the working facility is simple or confusing.

Holding-pen gates should be equal to or greater in length than the width of the alley. Alleys should be 10 to 12 feet in width. Wide alleys can be like large pens and allow cattle to escape past you. Narrow alleys, less than 10 feet, may force animals to come through you, rather than go around you, if their desire to escape is great.

Notice in the examples here how the gates become a part of the fence and effectively direct flow of the animals to and from the working area. Cattle typically travel to corners. Therefore, gates should be located in corners rather than the middle part of a fence line.

Examples of Holding Pen and Alley Designs

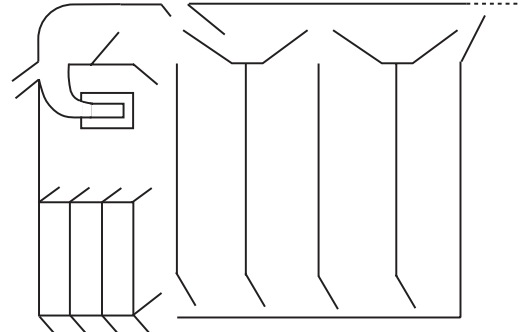
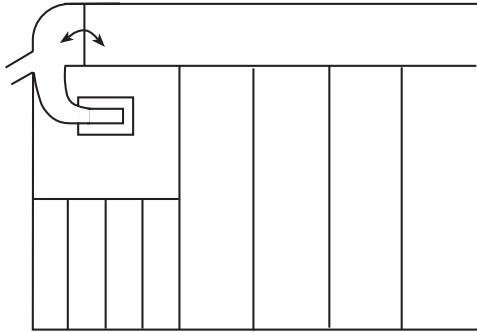

With alley on the side

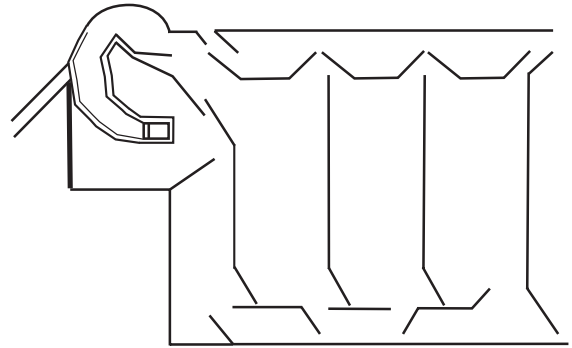
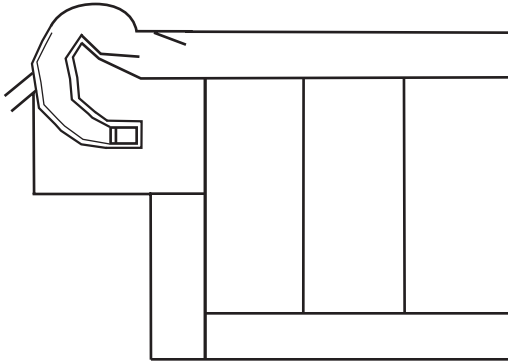

With two alleys

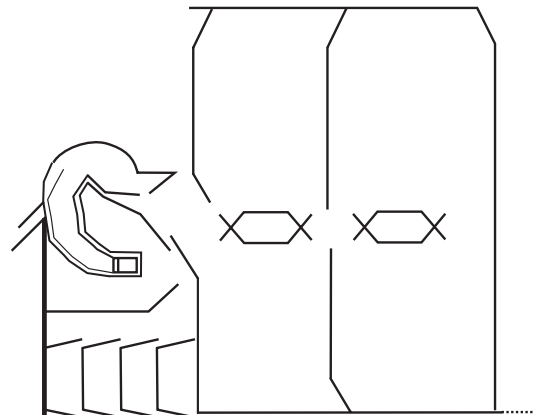
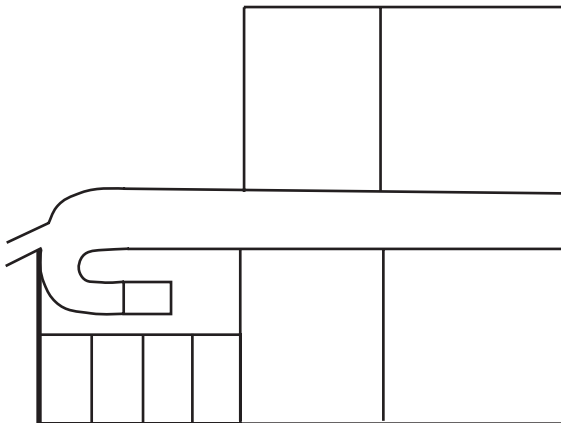

With a central alley

Crowding Pen or Crowding Tub

Use a crowding pen to funnel cattle into the working alley and chute. Handle small groups in crowding pens, eight to 10, instead of 20. For construction with straight fences, build one side of the crowding pen straight. The other side should be at an angle of about 30 degrees. Make the large end of the funnel 8 to 12 feet wide. Although it is harder to build, a circular crowding area with solid sides works best. Pre-built crowding pens can be purchased from cattle-handling equipment vendors.

Straight-Sided Crowding Pen

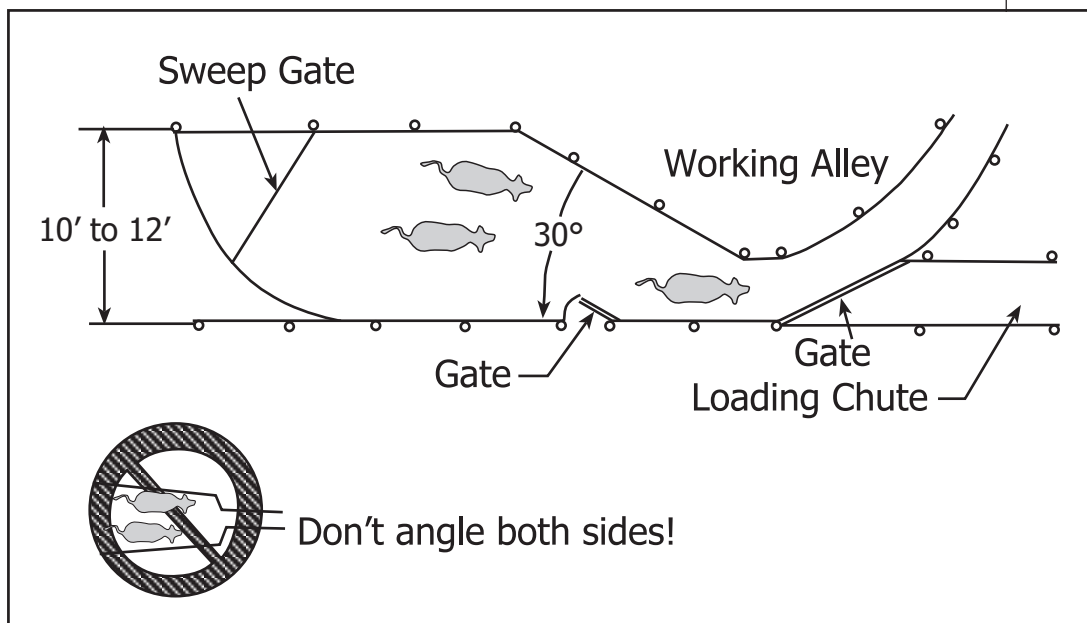

Circular Crowding Tub

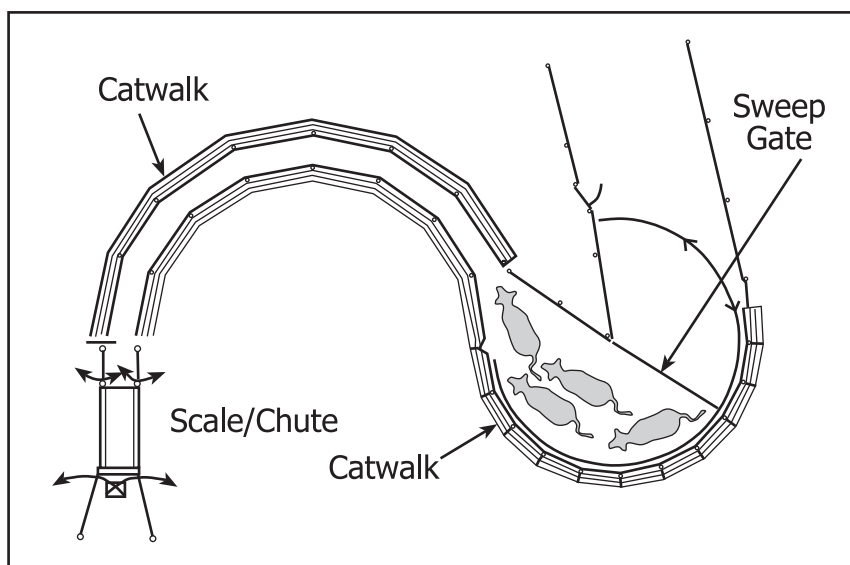

While there may be several gates in a corral that can benefit from being solid-sided, a gate in the crowding tub will benefit the most. A solid-sided gate will encourage animals to seek an alternative escape route — the working alley — rather than trying to turn around.

Example of a Solid-Sided Sweep Gate

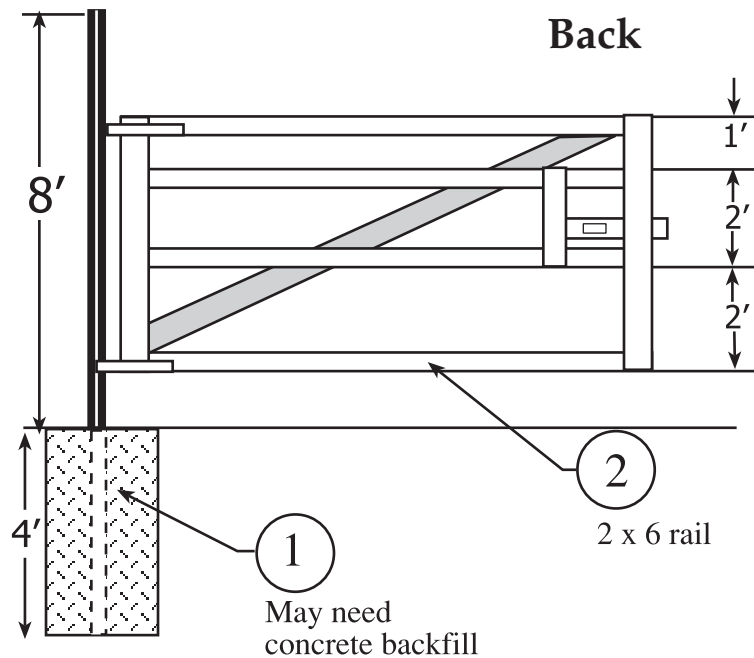
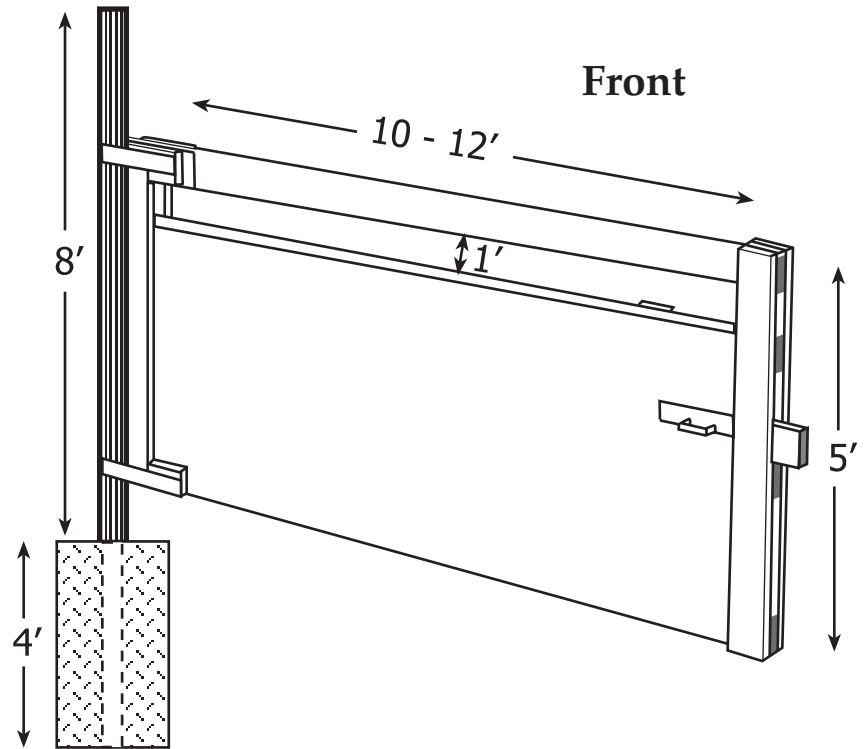

Rough concrete surfaces throughout a corral are ideal but may not be economically feasible. However, consider using concrete in the crowding tub, working alley, and restraining area.

Working Alley/Chute

Build working alleys at least 20 feet long. Shorter alleys cause delays in getting cattle to the working area. If you normally work cattle by yourself, an alley should be able to hold at least three animals for efficient labor utilization. Longer chutes can certainly be used. You may find spring loaded, back-stop gates useful to prevent cattle from backing up.

The width depends on the size of the animal. Build alleys 22 to 26 inches wide for small- to medium-frame cows. Eighteen inches is wide enough for calves. Commercial working alleys may be adjustable. One idea to consider for constricting the width of a “non-adjustable” alley is to hang a couple of plastic pipes in the alley when working calves.

Although they are harder to build, alleys with solid, sloping sides are better than those with vertical sides. A general recommendation is to build a five-foot-high alley 26 inches wide at the top and 16 inches wide at the bottom. Widths may need to be increased 2 to 4 inches for some large, exotic breeds.

Solid-sided working alleys can be built with wood or pipe frames covered with sheet metal or exterior plywood. Due to cost and ease of construction, straight alleys can be a reasonable choice for small herds. Emergency release panels, fences on hinges, could be considered if you are concerned about cattle getting down or falling backward. Pre-constructed, metal working alleys/chutes can be purchased from handling equipment vendors. These can also offer the option of being somewhat mobile.

Posts in the working alley receive a lot of pressure from the cattle. Use overhead crossbars to keep the posts in place and prevent them from bowing out. Further construction of overhead restrainers running parallel over the working alley will discourage rearing up or falling over backward in the working alley. Evaluate the height of the tallest animal you will work through a facility if your corral is to have overhead crossbars and restrainers.

Cattle will move forward more easily in an alley with solid sides. Solid, curved chutes keep cattle from seeing the working area until they are a few feet away. Avoid sharp bends that look like a dead end to cattle.

Cattle tend to move uphill easier than downhill. If there is much slope, point the alley uphill. Cattle also tend to move best from dark areas to light areas. Facility layouts should be designed so that cattle do not look directly into the sun.

Examples of Curved Working Alleys

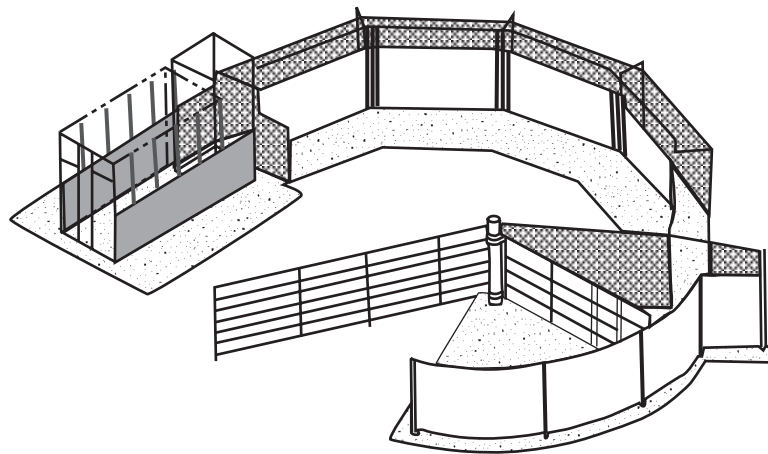
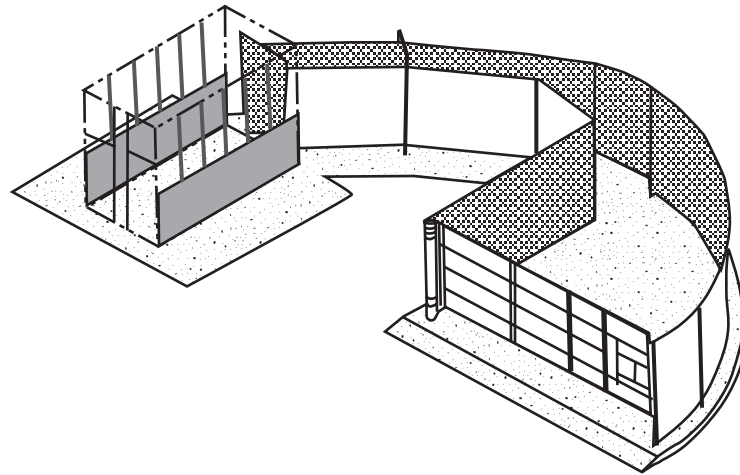

Restraining Area/Squeeze Chute or Headgate

The simplest way to create a working area is to securely fasten a head gate to the end of the working chute. Insert pipes or posts behind animals to prevent backing. A squeeze chute is more expensive than a headgate but gives you more control over the animal. Many vendors sell head gates, squeeze chutes, and fence panels. While plans are available, it is difficult to build a head gate or chute that works as well as those that are commercially available. Some new designs allow easier access to the neck region. All injections should be in the neck region.

To save climbing over the fence, build an entrance gate behind the squeeze chute or at the rear of the animal. The gate should swing into the chute to block the next animal and create a cage to protect the person working the cattle. Ideally, utilize a separate chute or breeding box for artificial insemination; this reduces the stress of the cow from her previous experiences in the working chute and headgate.

The working chute is a common location for the use of electrical equipment. To avoid exposure to electric shocks:

- Use a ground fault circuit interrupter with water heaters, clippers, and other equipment.
- Use moisture-proof electrical outlets in wet or damp areas.

Portable battery systems can be used as well. Boat batteries may have the most storage capacity.

Loading Chute

Cattle can be loaded on stock trailers from the working chute. If pick-ups are used, a loading chute is required. Make sure the height of the chute fits your truck and that you can back the truck squarely against the chute. If you use more than one type of truck, build an adjustable loading chute. Do not exceed 3-1/2 inches of rise per foot of length.

A flooring of packed earth or gravel provides the best footing but is not adjustable. On wooden floored chutes, use cleats that are one inch to two inches in height. Space cleats six inches to eight inches apart from edge to edge. Build loading chutes 30 inches wide for cow-calf operations.

Some Examples of Loading Chutes for Livestock Trailers

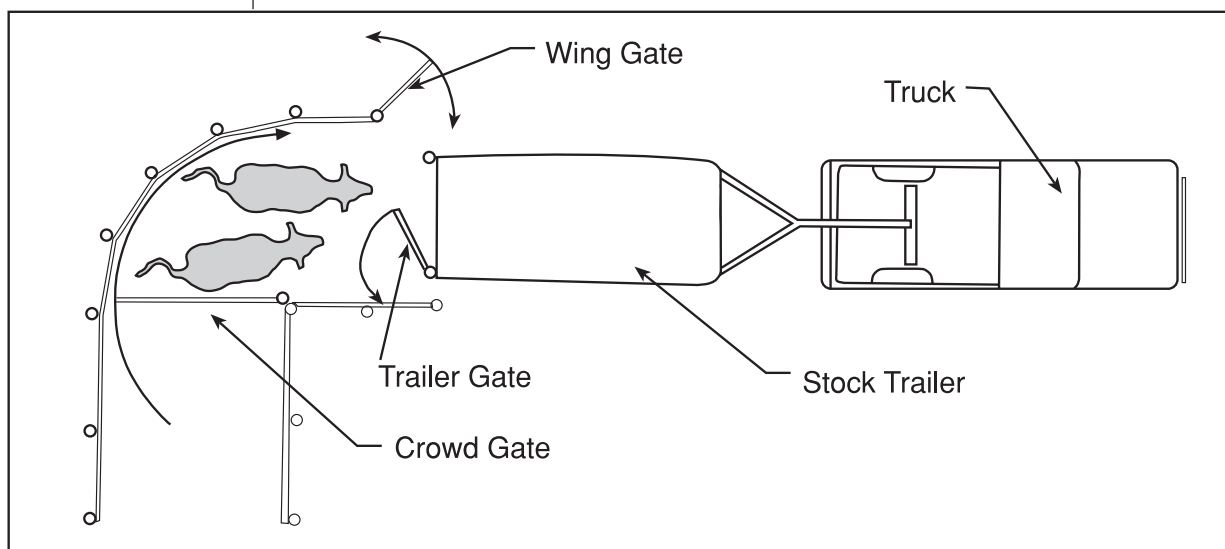
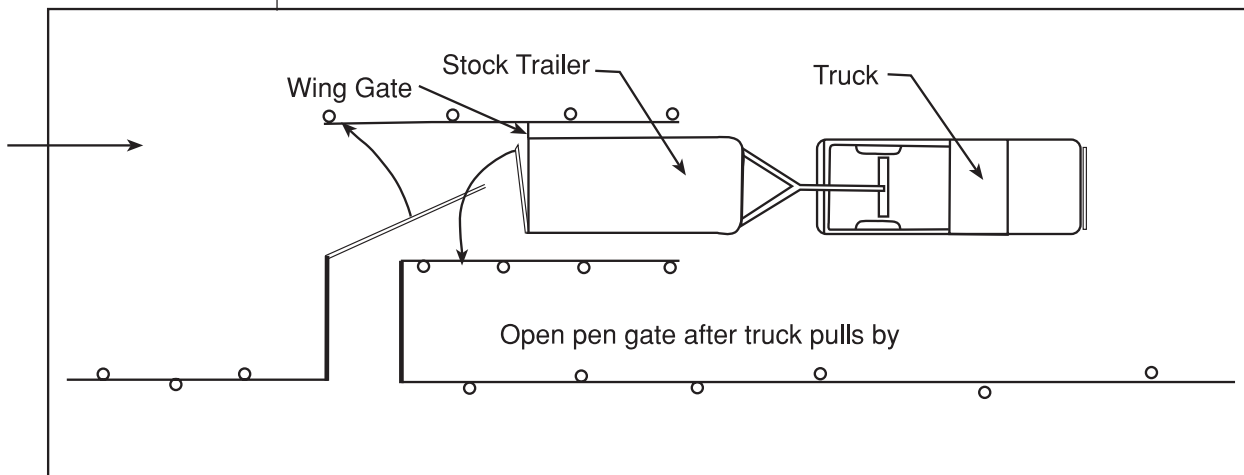

Materials

A layer of gravel in crowding and working chutes can prevent mud from becoming a problem. Concrete in heavy traffic areas is a good idea but only if it has a rough surface. Grooves one-inch deep and in an eight-inch diamond pattern improve footing.

Use pipe or wooden gates that will not easily bend or break. Hang gates six to eight inches from the ground so they swing freely. Use latches that can be operated from either side. Plywood on some sorting and crowding tub gates can help prevent turning.

Build fence five-feet high for most cattle. Fences for holding pens do not have to be as strong as those in working areas. Wire panels are available from most farm supply centers. Install two-inch by six-inch rails on the inside at the top of the posts, bottom and middle. This type of fence is not strong enough for the crowding area and working chutes.

Designs

You can check with your local county Extension office for corral designs. The most likely source for many plans may be Midwest Plan Service (1-800-562-3618 or www.mwpshq.org).

Dr. Temple Grandin also maintains some excellent materials on corral design and animal behavior at <http://www.grandin.com/>. Thomas Bean has an excellent Ohio State University Extension fact sheet on *Working Safely With Livestock* located at <http://ohioline.osu.edu/aex-fact/0990.html> or available from your local OSU Extension Office.

The following are some simplified designs for smaller cow herds.

Example 1

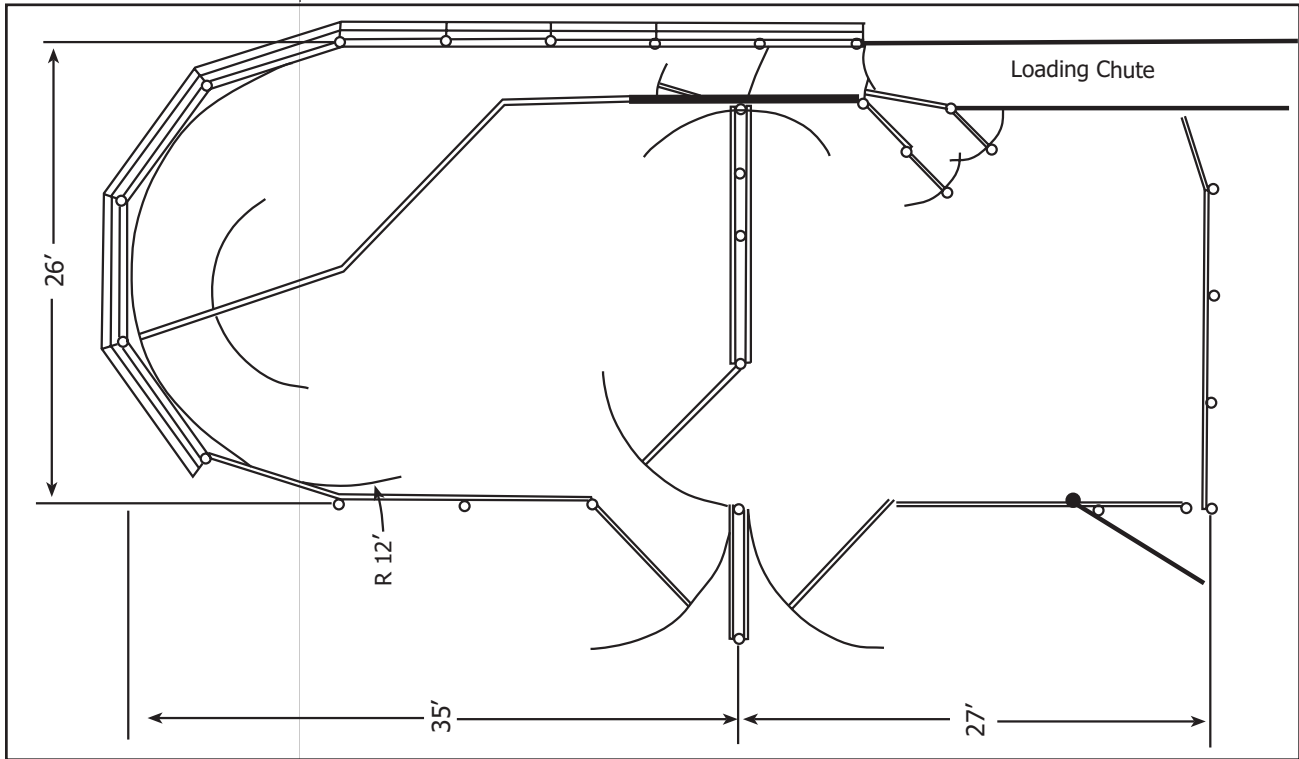

Example 2

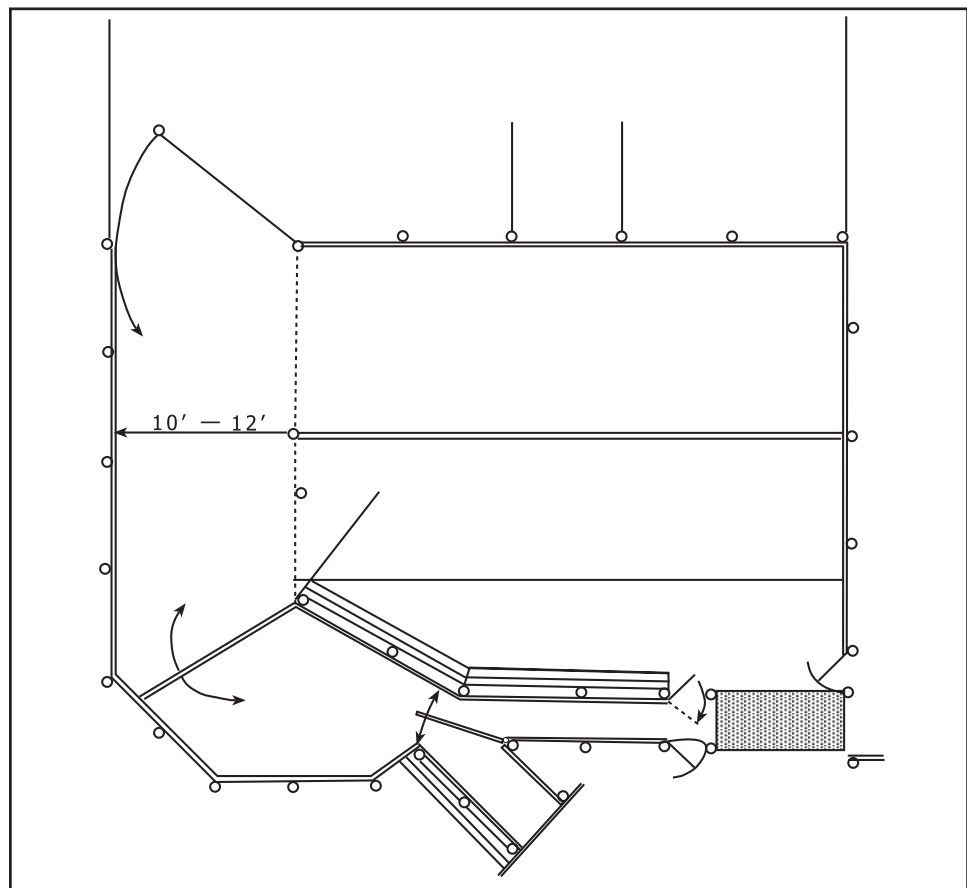

Corral and Working Facility Dimensions			
	<u>To 600 lb</u>	<u>600-1,200</u>	<u><1,200 and Cow-Calf</u>
Pen Space (sq ft/head)	14	17	20
Crowding Tub (sq ft/head)	6	10	12
Working Chute-vertical sides			
Width (inches)	18	20-24	26-30
Minimum Length (feet)	20	20	20
Working Chute-sloping sides			
Width at Bottom (inches)	13	15	16
Width at Top (inches)	20	24	28
Minimum Length (feet)	20	20	20
Working Chute Fence			
Height—minimum	45	50	60
Depth of Posts—minimum	30	30	30
Corral Fence			
Height	60	60	60
Depth of Posts—minimum	30	30	30
Loading Chute			
Width (inches)	26	26	26-30
Length (minimum, feet)	12	12	12
Rise, in/ft	3 ¹ / ₂	3 ¹ / ₂	3 ¹ / ₂
Dimensions from <i>Corral and Working Facilities for Beef Cattle</i> . GPE-5002			

